

AUTOMATIC RAILWAY STATION DISPLAY

ANISH M T

DON A ALEXANDER

JASAM K

RAJEESH BABU T P



INTRODUCTION

- It is the system , that display the forthcoming station in the compartment
- There are many method is exiting
- Low cost & low power compare with other methods
- This is simple and economic

PRINCIPLE OF OPERATION

- Unique property of railway-there is no obstacle.
- Ultrasonic signal tran-upward which is reflected by the electrical post and counted
- Receiver detected and set the counter &compare store values
- station name displayed

Railway details

- Distance b/w two electric posts = **18m-78m**
- Thickness of the bar = **4.3cm**
- Maximum speed of the train = **90km/hr**
- Time take to pass one post = **0.78sec-2.88sec**
- The average no. of posts = **1200-1500**

COUNTER

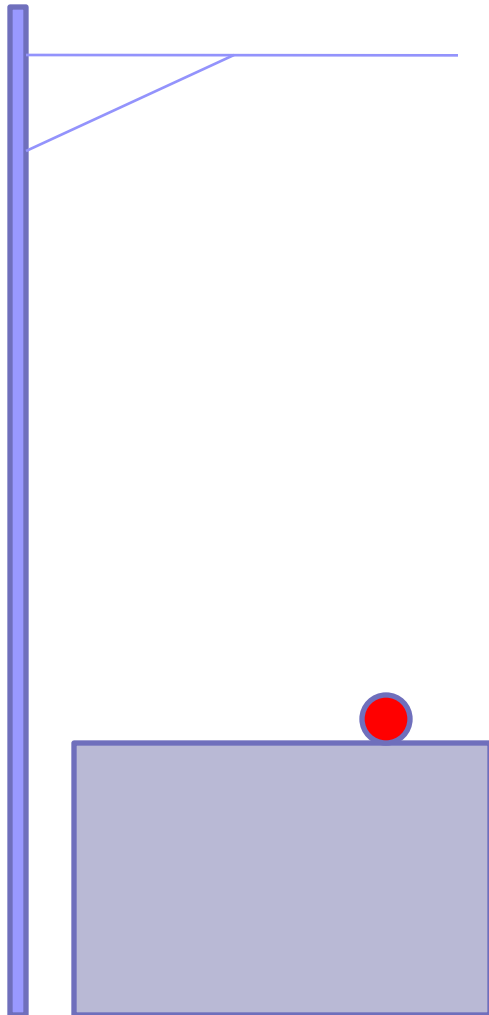
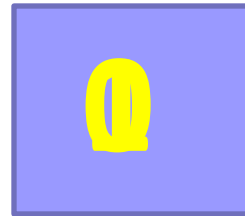

COUNTER

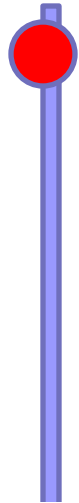
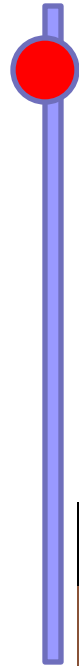
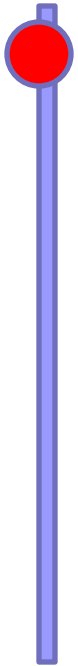
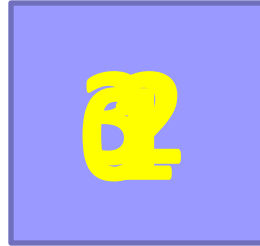

OVER BRIDGE

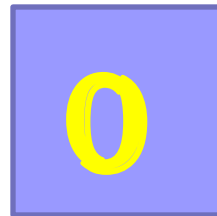
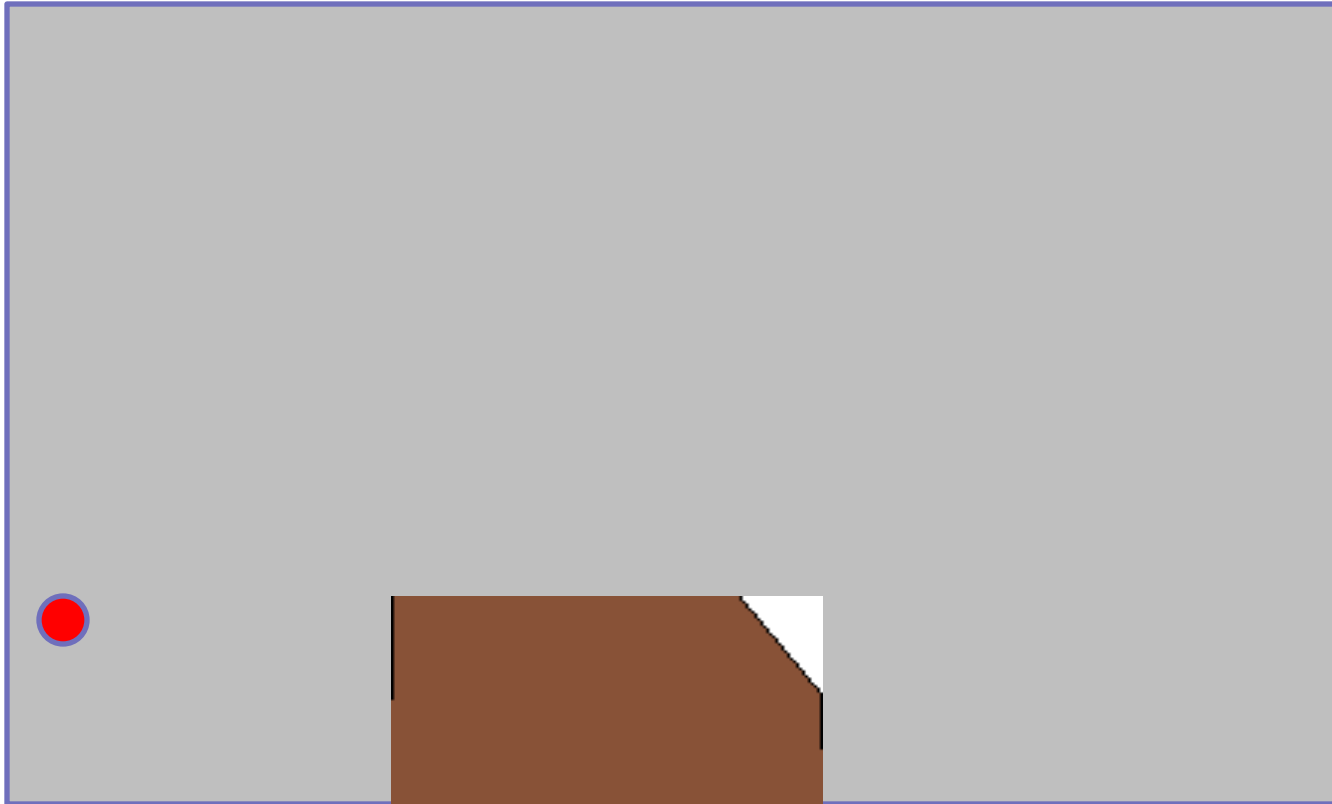

COUNTER

BLOCK DIAGRAM

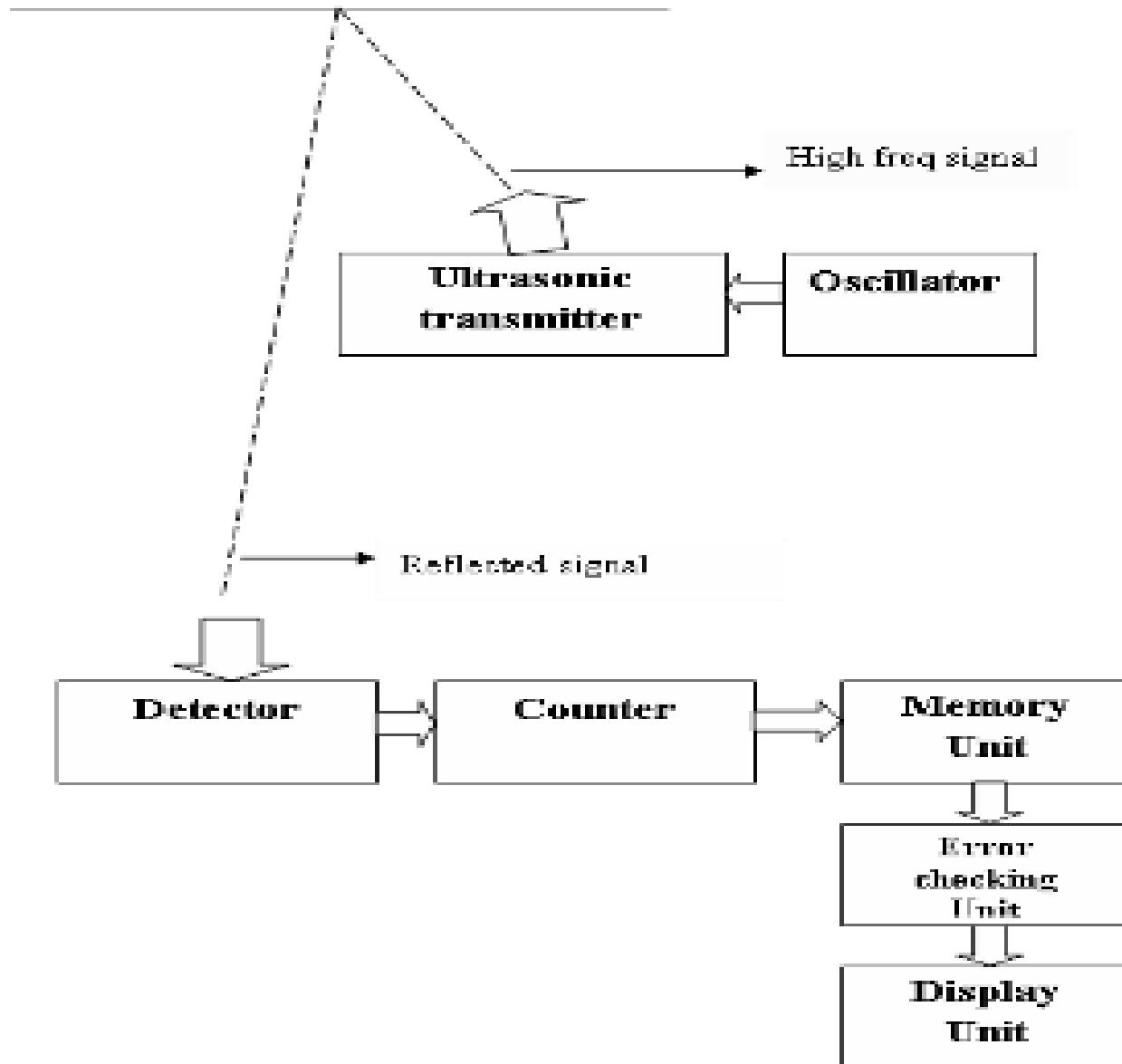



Block division

- Section-1:(ultrasonic tran-receiver)
- Section-2 (counter & error checking)
- Section-3 (display unit)

Working

- 12F675 pic - generate the 40 KHz signal.
- Level logic converter (MAX232) which convert to TTL output pulse to +12v and -12v pulse.
- Then transmitted.
- Reflected weak signal amplified wave is given to zero adjustment amplifier because the amplified wave is in the range of above 6v level.

Contd....

- Then o/p is given to comparator converted into corresponding square wave signal.
- Then the square wave signal is given to input of the microcontroller.
- Now the microcontroller compares the time between the transmitted signal and received transistor.

Section-2

Counter & error checking

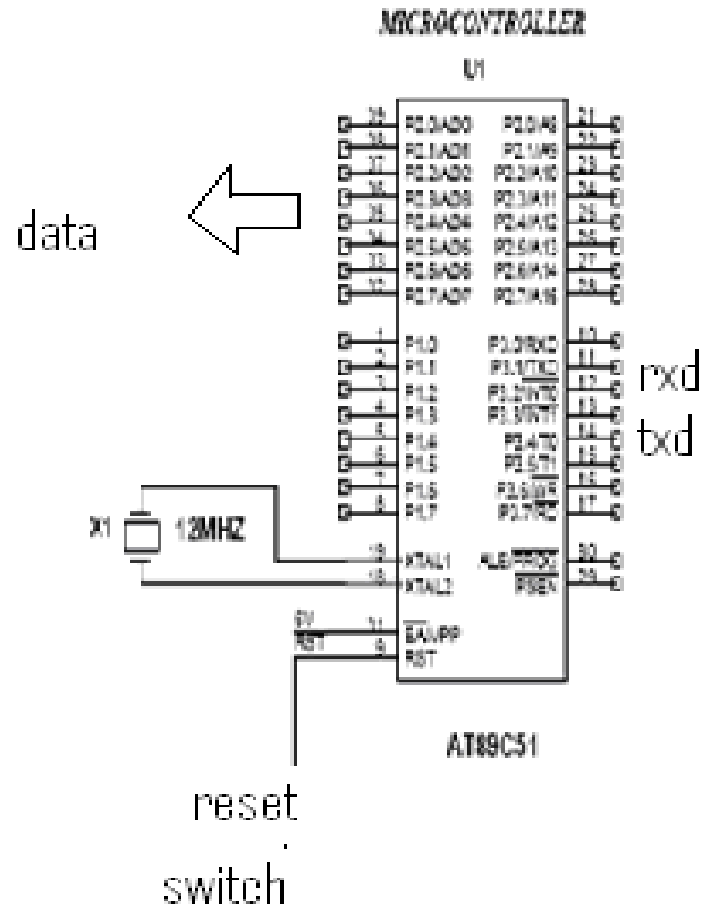

AT89C51

- TXD pin transmit a pulse
- When a pulse received at RXD set a counter
- Compare this value with pre-assigned data
- Corresponding data is transmitted to port-0

Section-3

display unit—2x16 LCD DISPLAY



LCD connector

LCD CONNECTOR

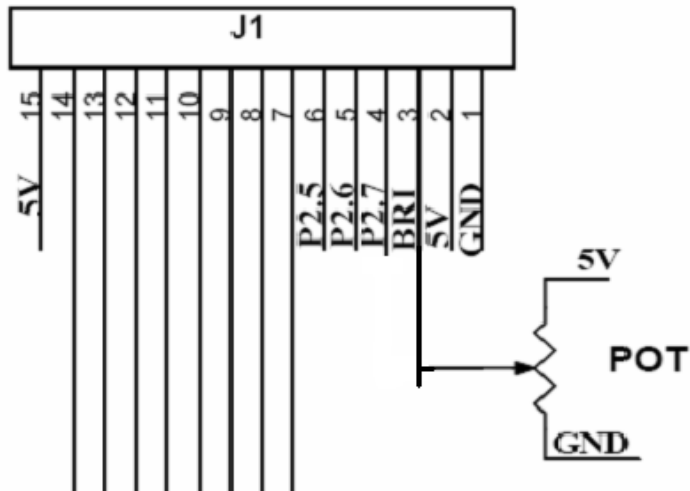

- 6-en
- 5-W/R
- 4-RS (0-command, 1-data)
- 3-brightness

Overall circuit

ULTRASONIC BASED RAILWAY STATION IDENTIFIER

ULTRASONIC TRANSMITTER/ RECEIVER

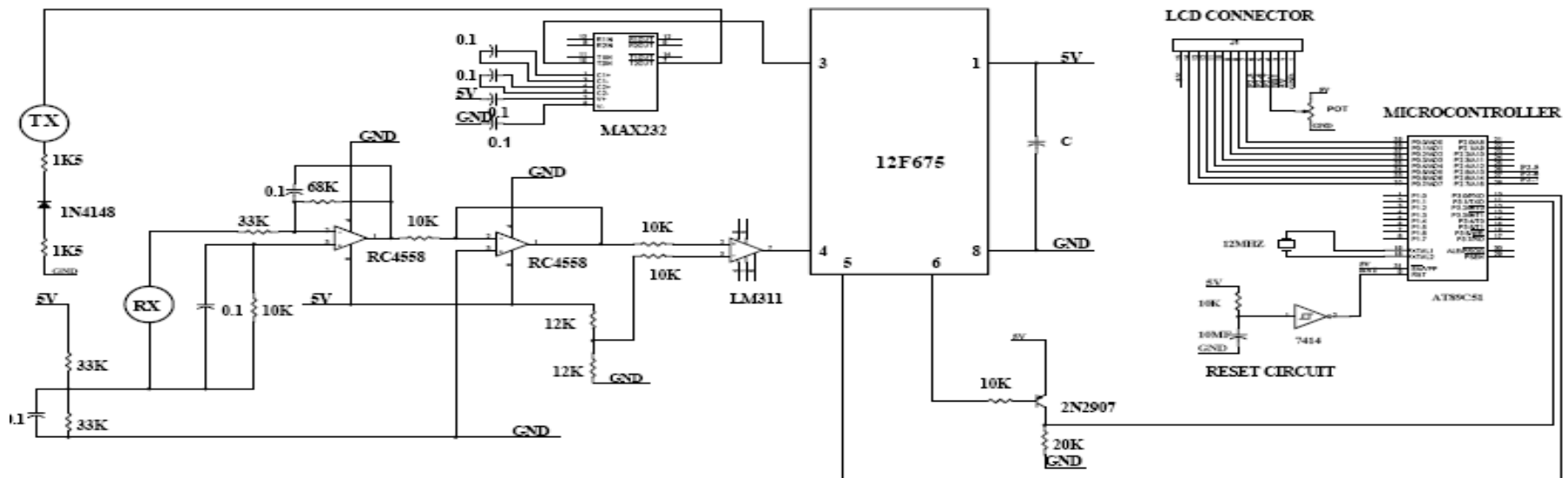

POWERSUPPLY

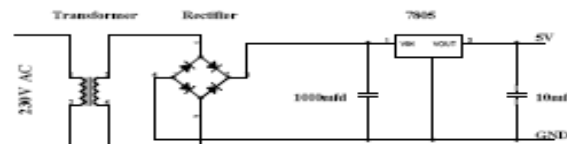



ADVANTAGES

- PORTABLE MODULES
- EASY TO USE
- SIMPLE & CHEAP
- EASY TO IMPROVE



LIMITATION

- **LESS EFFICIENCY**
- **HIGH ERROR PROBABILITY**



Future improvement

- We can improve sensitivity –high directive antenna
- Improve the efficiency-more modules

Hardware

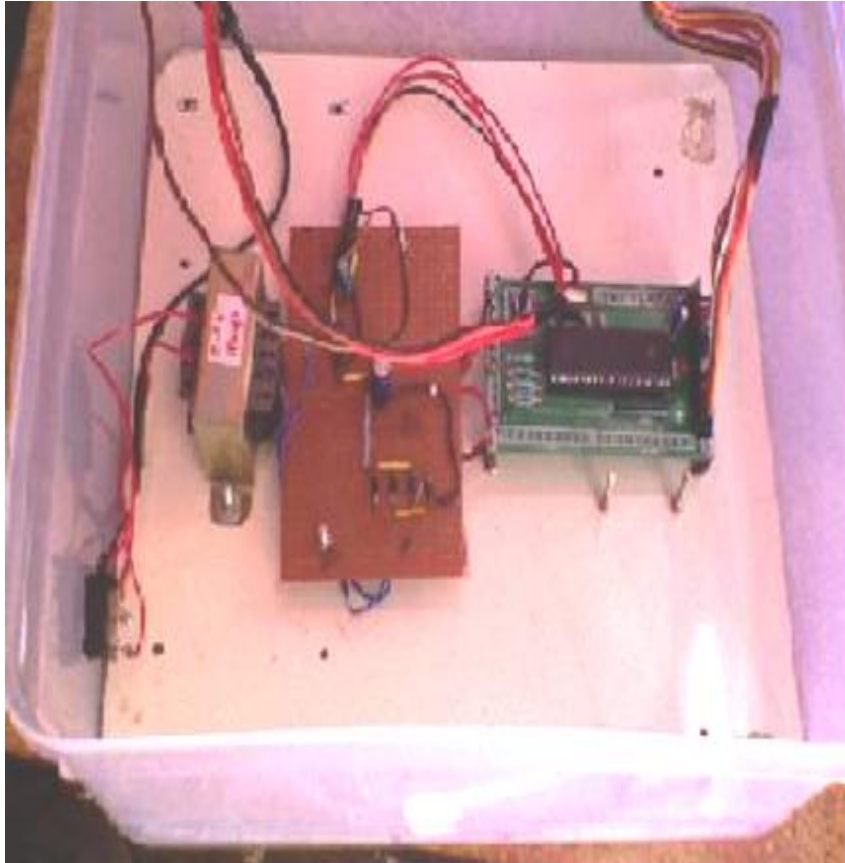

REFERENCE

- www.microchip.com
- www.alldatasheets.org
- www.rentron.com
- www.indianrail.gov.in
- www.efymag.com
- Electronics for you magazine



THANK YOU