

SYNOPSIS

Objective:

The objective of this project is to control the position of a solar panel in accordance with the motion of sun.

Brief Methodology:

This project is designed with solar panels, LDR, ADC, Microcontroller, Stepper Motor and its driving circuit.

In this project two LDRs are fixed on the solar panel at two distinct points. LDR (Light Dependant Resistor) varies the resistance depending upon the light fall. The varied resistance is converted into an analog voltage signal. The analog voltage signal is then fed to an ADC.

ADC is nothing but analog to digital Converter which receives the two LDR voltage signals and converts them to corresponding digital signal. Then the converted digital signal is given as the input of the microcontroller. Microcontroller receives the two digital signals from the ADC and compares them. The LDR signals are not equal except for normal incidence of sunlight. When there is a difference between LDR voltage levels the microcontroller programme drives the stepper motor towards normal incidence of sunlight.

1) INTRODUCTION

Renewable energy is rapidly gaining importance as an energy resource as fossil fuel prices fluctuate. At the educational level, it is therefore critical for engineering and technology students to have an understanding and appreciation of the technologies associated with renewable energy.

One of the most popular renewable energy sources is solar energy. Many researches were conducted to develop some methods to increase the efficiency of Photo Voltaic systems (solar panels). One such method is to employ a solar panel tracking system .This project deals with a micro

controller based solar panel tracking system. Solar tracking enables more energy to be generated because the solar panel is always able to maintain a perpendicular profile to the sun's rays.

Development of solar panel tracking systems has been ongoing for several years now. As the sun moves across the sky during the day, it is advantageous to have the solar panels track the location of the sun, such that the panels are always perpendicular to the solar energy radiated by the sun. This will tend to maximize the amount of power absorbed by PV systems. It has been estimated that the use of a tracking system, over a fixed system, can increase the power output by 30% - 60%. The increase is significant enough to make tracking a viable proposition despite of the enhancement in system cost. It is possible to align the tracking heliostat normal to sun using electronic control by a micro controller.

Design requirements are:

- 1) During the time that the sun is up, the system must follow the sun's position in the sky.
- 2) This must be done with an active control, timed movements are wasteful. It should be totally automatic and simple to operate. The operator interference should be minimal and restricted to only when it is actually required.

The major components of this system are as follows.

- 1) Input photo transducer (LDR).
- 2) Analog to digital converter.
- 3) Microcontroller.
- 4) Tracking software.
- 5) Output mechanical transducer (stepper motor).

BLOCK DIAGRAM

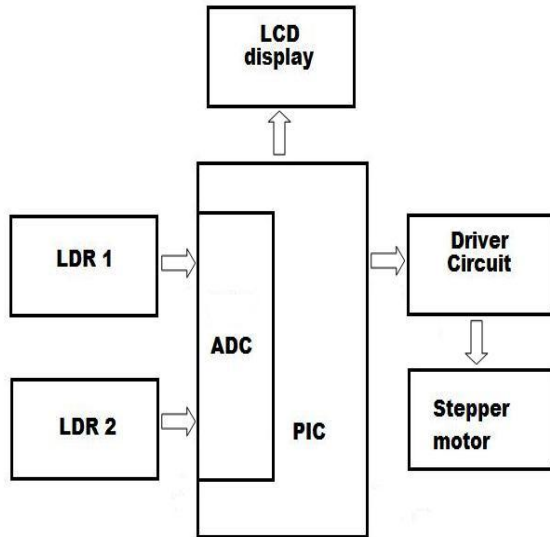

BIBLIOGRAPHY

❖ REFERENCE BOOKS

- Piao Z G, Park J M, A study on the tracking photovoltaic system by programme type
- Yousef H A, Design and implementation of a Fuzzy Logic Computer-Controlled Sun tracking system
- Saxena, A K Dutta, A Versatile microcontroller based solar tracking system

❖ WEBSITES

- <http://mathforum.org/library/drmath/view/56477.html>
- www.IEEE.com

Sent by Amal Kamal