

# **Advanced Power Saving Iron Box**

## **ABSTRACT**

Advanced Power Saving Iron box is a new type of Iron box which is capable of saving power. It saves the power by switching OFF the Iron box while it is not in use. The idle condition of Iron box is detected by two types of sensors. One checks the presence of user's hand and the other checks the position of Iron box. The idle time is mainly indicated by the absence of user's hand. The time counting circuit checks the sensor states and counts the idle time. The comparator compares whether the counting reached the preset count. If so it automatically cut off the supply to the Iron box in horizontal position. In the vertical position of Iron box, the circuit waits a little more time to cut off the supply.

## **BLOCK DIAGRAM**

The block diagram for the power saving iron box is given below. The power is saved by cutting the supply to the iron box off while it is not in use. This is achieved by sensing the presence of user's handle on the iron box and the position of iron box. Whenever the user's hand is not present on the handle the optical sensor sends a signal to the control & resetting circuit timing circuit which allows the clocks entering the timer (counter). The basic time unit (time for a clock) is set on the clock generator. The counter counts the time and the comparator compares the counted time with the preset time set on it. At the same time the tilt sensor senses the position of the iron box (whether horizontal or vertical) and sends a signal depending upon the position. If the counted time is greater than the preset time the comparator signals the relay to cut the supply to the iron box off. If the relay is off it is sends a signal to control & resetting circuit to prevent the counter from further counting. Thus iron box remains in off state.

The presence of hand resets the counted time, which enables the supply to iron box.

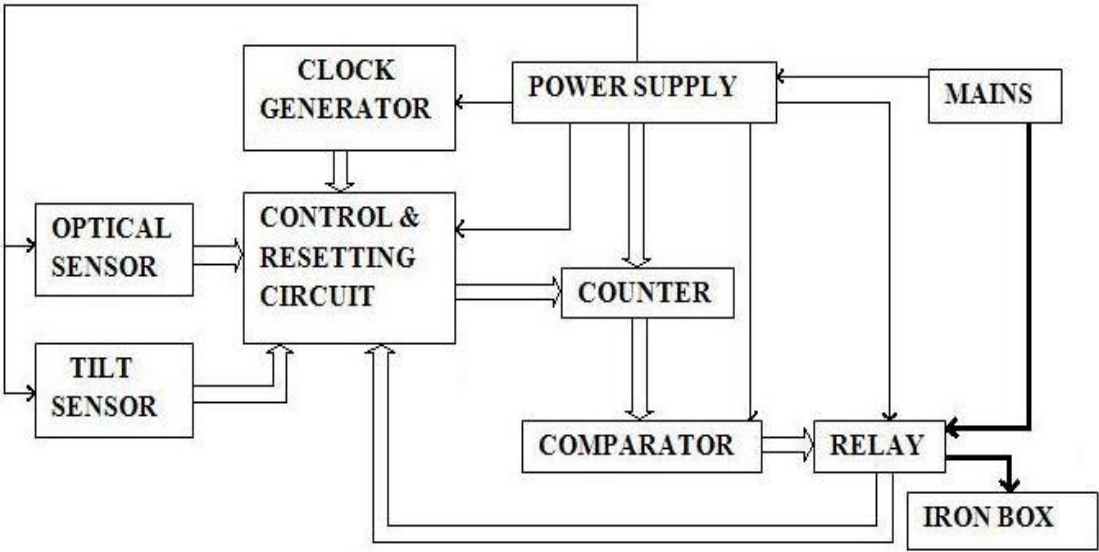

Done by

Arunkumar T A, Anju K P, Saleej K, Shabeer Ali K.

arunkumarpeechi@gmail.com.